

# High Clearance Traction Rods Installation Instructions SPL RTRHC R35

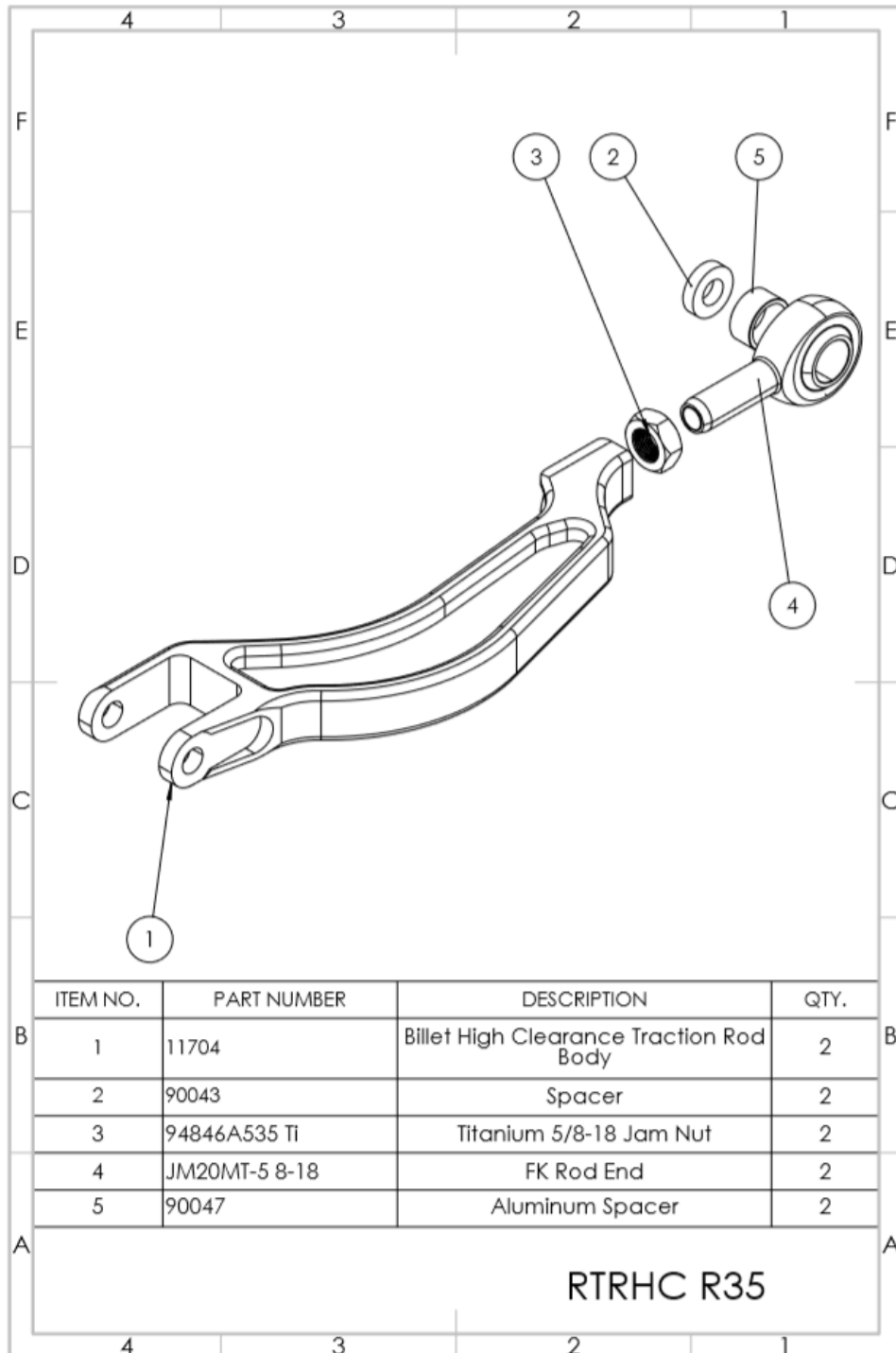

Thank you for your purchase of this SPL Parts performance suspension product. Please follow these instructions exactly to ensure that the product is able to function to the best of its ability, and you can achieve the most performance out of your vehicle.

1. Remove the stock traction arm from your vehicle.
2. Measure from the center of the bolt hole to the center of the bolt hole on the opposite end of the OEM arm and set your SPL Parts Rear Traction Arm to that length. Make sure you do not exceed maximum extension of the FK Rod End (4), which is a 5/8" extension.
3. Attach the SPL Parts Arm to arm to the subframe. Make sure to install the FK Rod End right up against the chassis to give maximum wheel clearance as shown below. Use the aluminum spacer (5) to fill the rest of the space on the stud between the rod end and the bolt. If the nut bottoms out before the arm is tight, use the Spacer (4). (Picture is older design with the Double Adjuster. The new design of the Arm does **not** have the Double Adjuster).

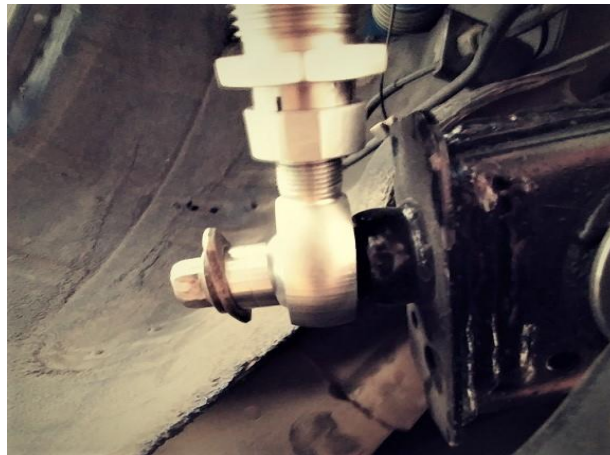

4. Attach the SPL Parts Rear Traction Arm to the knuckle by reusing the factory nut and bolt as shown.
5. Torque all of the bolts to factory specs and make final adjustments.
6. Have the car professionally aligned. Take these instructions with you to ensure that the arms are adjusted correctly.
7. Be safe and enjoy your new upgrade!

## **ONE-YEAR LIMITED WARRANTY AND DISCLAIMER**

All SPL brand products are intended for **Off Road Use Only** and carry a one year limited warranty. See below for details. All other branded products carry their respective manufacturer warranty.

SPL PRO suspension products warranted to be free of defects in material and workmanship for one (1) year from the date of purchase.

If a product fails to meet specifications, SPL PARTS INC will, at its election, repair, replace, or make appropriate adjustment, if SPL PARTS INC determines to its satisfaction that the product is defective in material or workmanship, i.e. contains a defect arising out of the manufacture of the product and not a defect caused by other circumstances, including, but not limited to accident, misuse, abuse, unforeseeable use, neglect, alteration, improper installation, improper adjustment, improper repair, or failure caused by other equipment or interaction with other equipment. SPL PARTS INC is not responsible for labor charges, removal charges, installation, or other incidental or consequential costs. In no event shall the liability of SPL PARTS INC exceed the purchase price of the product.

SPL PARTS INC makes no other warranties, either expressed or implied, including limitation warranties as to merchantability or fitness for a particular purpose. SPL PARTS INC shall not be liable for, and buyer assumes all risk of, any advice or failure to provide advice by SPL PARTS INC to buyer regarding the product or use and installation of product. SPL PARTS INC shall not be liable for any special, incidental or consequential damages.

If the purchaser of the product shall fail to pay when due any portion of the purchase price, or fail to meet any terms required under contract agreed on at time of purchase, all warranties and remedies granted may be terminated.

**Using any SPL arm as a tie/strap down point for a dyno session or transport will void the warranty.**