

# Front Tie Rod Ends Kit Installation Instructions SPL TRE Z34

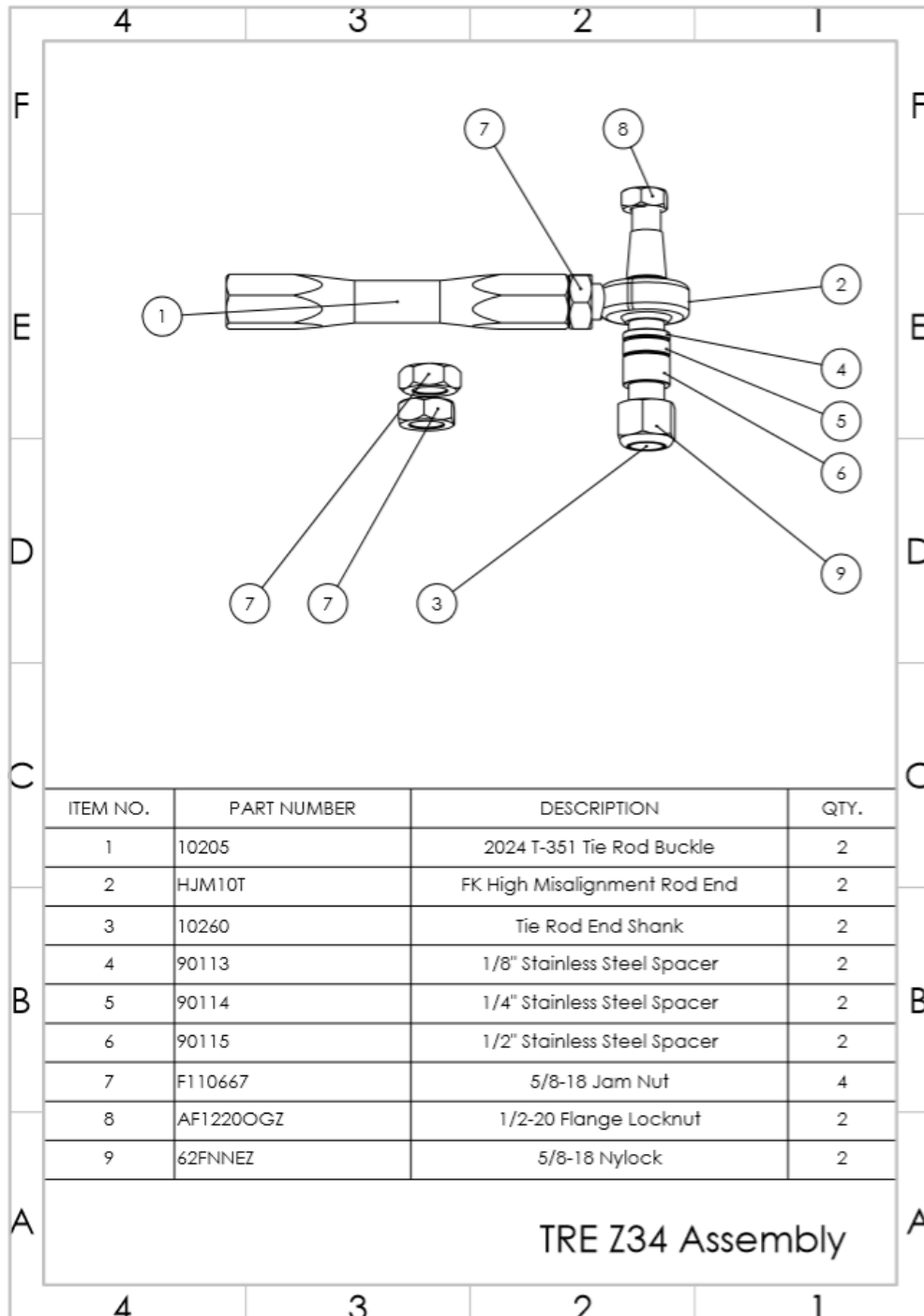

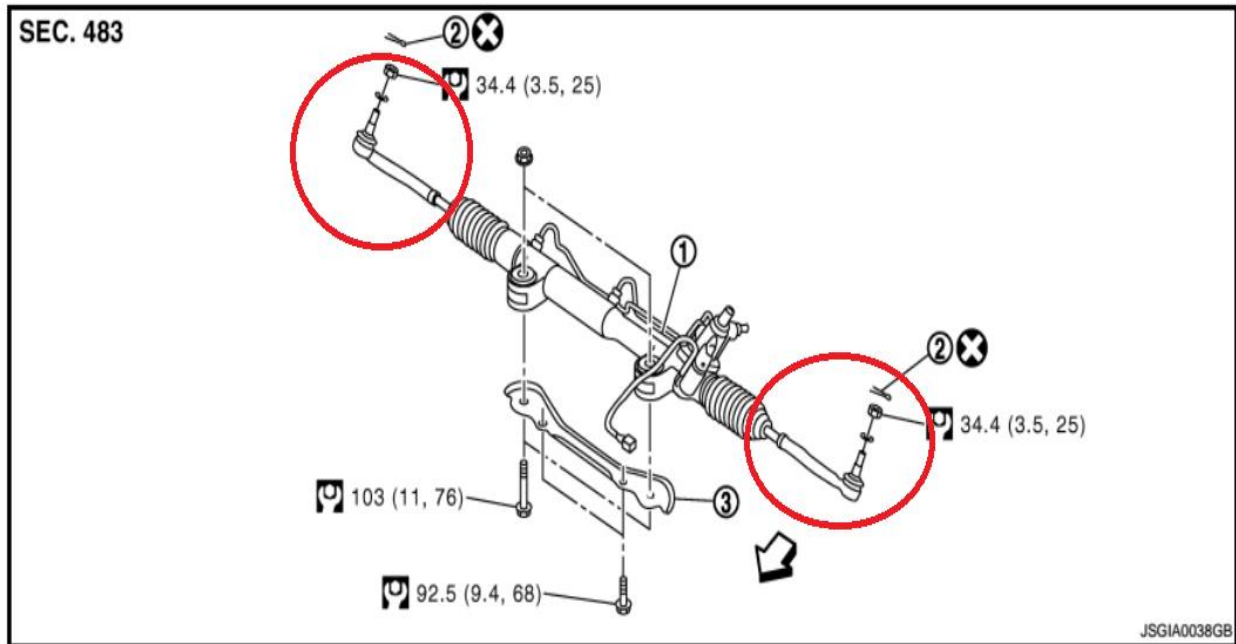

Thank you for your purchase of this SPL performance suspension product. Please follow these instructions exactly to ensure that the product is able to function to the best of its ability, and you can achieve the most performance out of your vehicle.

1. Raise the front of the vehicle and place jack stands in the OEM recommended locations.
2. Remove the front wheels from the car and put them aside.
3. Remove the factory tie rod ends. These parts are circled in red in the image above.
4. Insert the tie rod shank (3) into the spindle. Use the two supplied 5/8" regular (non-locking) nuts (7) and jam the nuts together to help hold the tie rod shank. Torque the nut on top of the knuckle to **75 ft.-lbs.** Do not use an impact gun or over torque, as the strength of the tie rod end will be severely compromised. SPL Parts is not liable for any issues due to overtorque.



5. Remove the two nuts and install the spacers. As pictured on the left, the tie rod ends are installed with one adjustment spacer (flat ring spacer) and one misalignment spacer (large cone shaped spacer). Install the locking nut on the bottom. This nut will take some effort to thread (about 20 **ft.-lbs.** of torque) as it is a metal crimping locking nut. Torque to 80 **ft.-lbs.**



The following pictures show possible bump steer adjustment settings, using various combinations of spacers. The stock tie rod end corresponds to the setting in image #3 (with two adjustment spacers and no misalignment spacer).

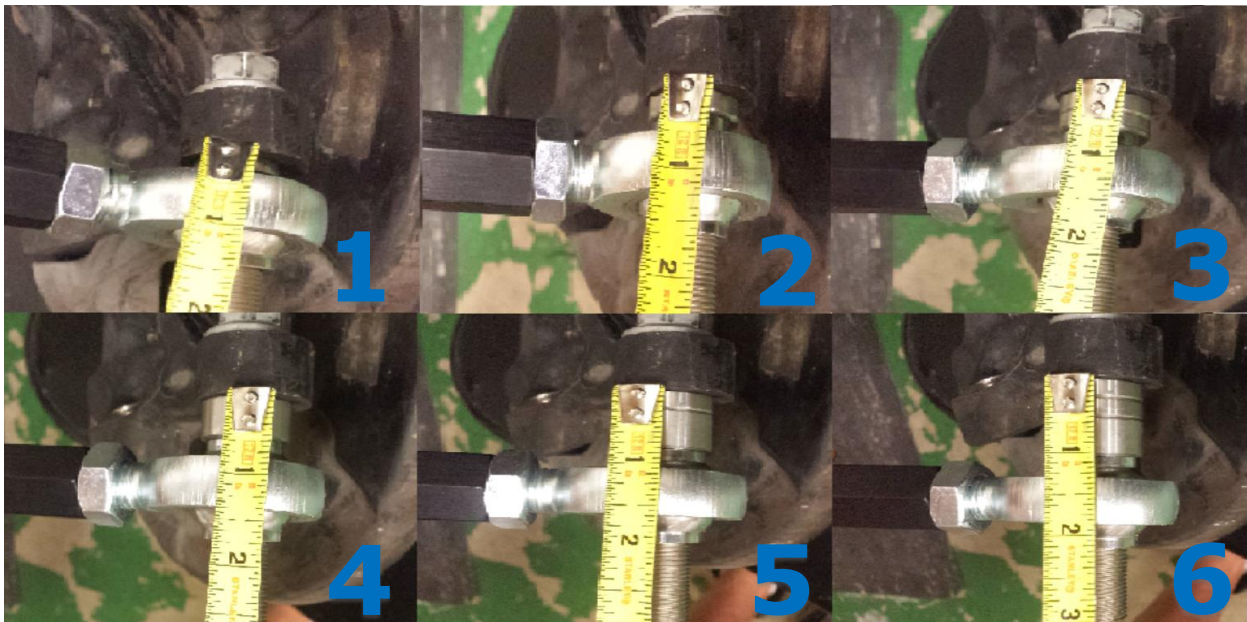

For most installations on stock knuckles, we recommend using **the setting in the fourth image above (one misalignment spacer, no adjustment spacers).**

Verify there are no clearance issues with the knuckle, subframe, or other suspension arms before putting the car back on the ground.

Check for binding or any problems by rotating the steering wheel lock-to-lock. Check that the spherical bearing does not bind (the edge of the ball bearing hitting or close to hitting the housing) under any situation as shown in the pictures below. After installing, run the suspension and the steering rack from lock-to-lock through its travel to make sure there is no contact between the arms.



Note that the inner tie rod end can rotate freely, so the picture on left is not binding even though the edge of the ball is touching the housing.

If uncertain, try rotating the inner tie rod by using a wrench on the hex part of the inner tie rod. To do this, tighten down the two jam nuts that go against the hex buckle of the outer tie rod end. Any excess thread below the bottom nut can be trimmed or cut off as needed (e.g. for wheel or steering bump stop clearance).

When getting the car aligned, please adjust toe by turning the inner tie rod. Do not turn the tie rod end buckle, as this will not adjust toe.

### **Length adjustment of outer tie rod ends**

SPL tie rod ends are preset to a specific length, but in certain cases it may be necessary to make the outer tie rod ends longer or shorter. The outer tie rod ends can be lengthened or shortened on the car using the following procedure:

1. Loosen the jam nuts on both sides of the hex buckle.
2. Hold the inner tie rod fixed and turn the hex buckle to thread in/out the rod end (spherical bearing side). Note that both the rod end and the inner tie rods are right hand thread. Threading in/out the rod end will in turn thread out/in the buckle on the inner tie rod side.
3. Once the outer tie rod end is long/short enough, tighten down the jam nut on the rod end side. Note that for safe thread engagement,

the maximum amount of exposed thread on the rod end should not exceed 0.7".

4. Follow the normal procedure of turning the inner tie rod to adjust the toe.

Be safe, and enjoy your new upgrade!

## **ONE-YEAR LIMITED WARRANTY AND DISCLAIMER**

*All SPL brand products are intended for **Off Road Use Only** and carry a one year limited warranty. See below for details. All other branded products carry their respective manufacturer warranty.*

*SPL PRO suspension products warranted to be free of defects in material and workmanship for one (1) year from the date of purchase.*

*If a product fails to meet specifications, SPL PARTS INC will, at its election, repair, replace, or make appropriate adjustment, if SPL PARTS INC determines to its satisfaction that the product is defective in material or workmanship, i.e. contains a defect arising out of the manufacture of the product and not a defect caused by other circumstances, including, but not limited to accident, misuse, abuse, unforeseeable use, neglect, alteration, improper installation, improper adjustment, improper repair, or failure caused by other equipment or interaction with other equipment. SPL PARTS INC is not responsible for labor charges, removal charges, installation, or other incidental or consequential costs. In no event shall the liability of SPL PARTS INC exceed the purchase price of the product.*

*SPL PARTS INC makes no other warranties, either expressed or implied, including limitation warranties as to merchantability or fitness for a particular purpose. SPL PARTS INC shall not be liable for, and buyer assumes all risk of, any advice or failure to provide advice by SPL PARTS INC to buyer regarding the product or use and installation of product. SPL PARTS INC shall not be liable for any special, incidental or consequential damages.*

*If the purchaser of the product shall fail to pay when due any portion of the purchase price, or fail to meet any terms required under contract agreed on at time of purchase, all warranties and remedies granted may be terminated.*

***Using any SPL arm as a tie/strap down point for a dyno session or transport will void the warranty.***

