

Rear Traction Rods Kit Installation Instructions SPL RTR Z34

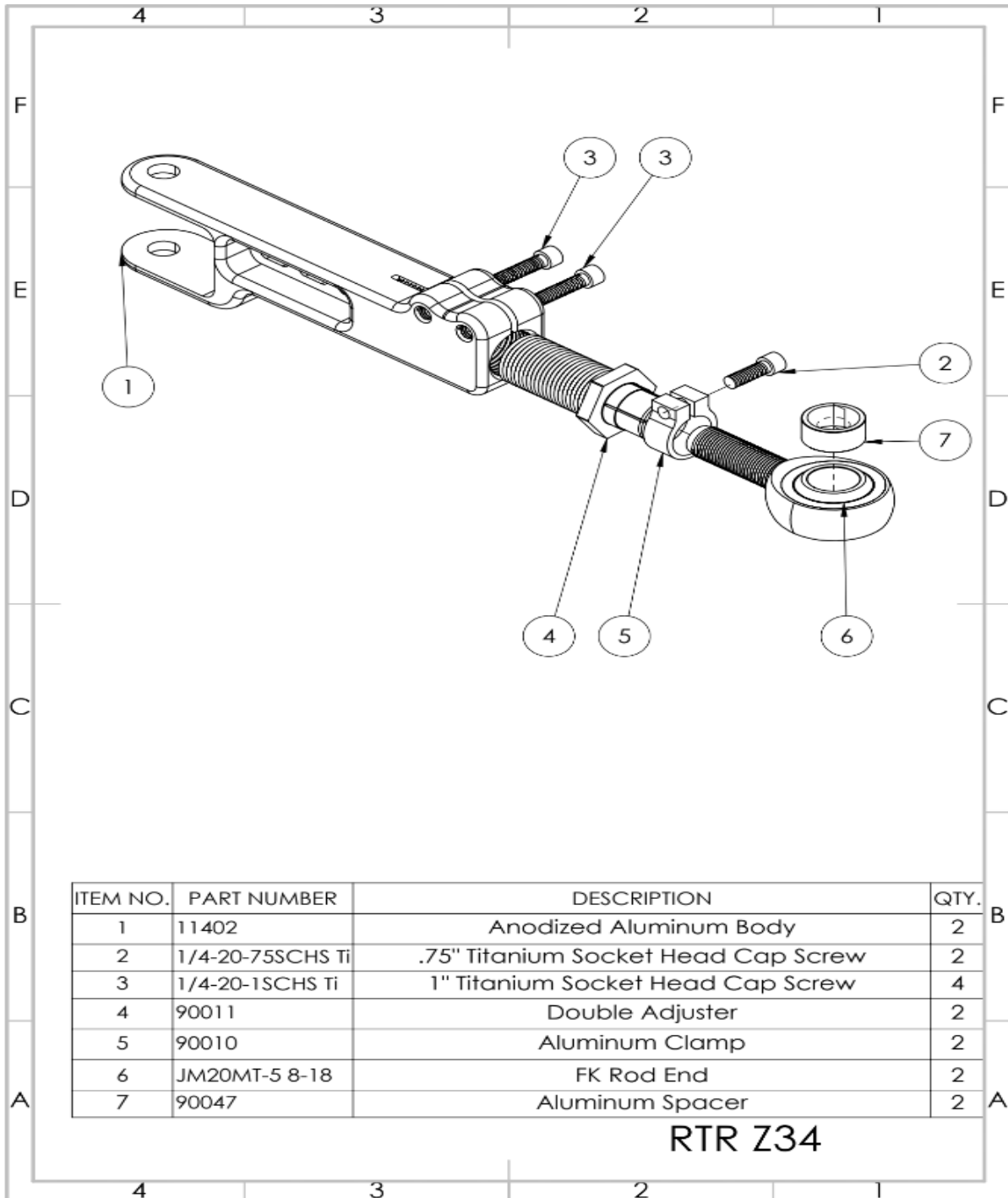

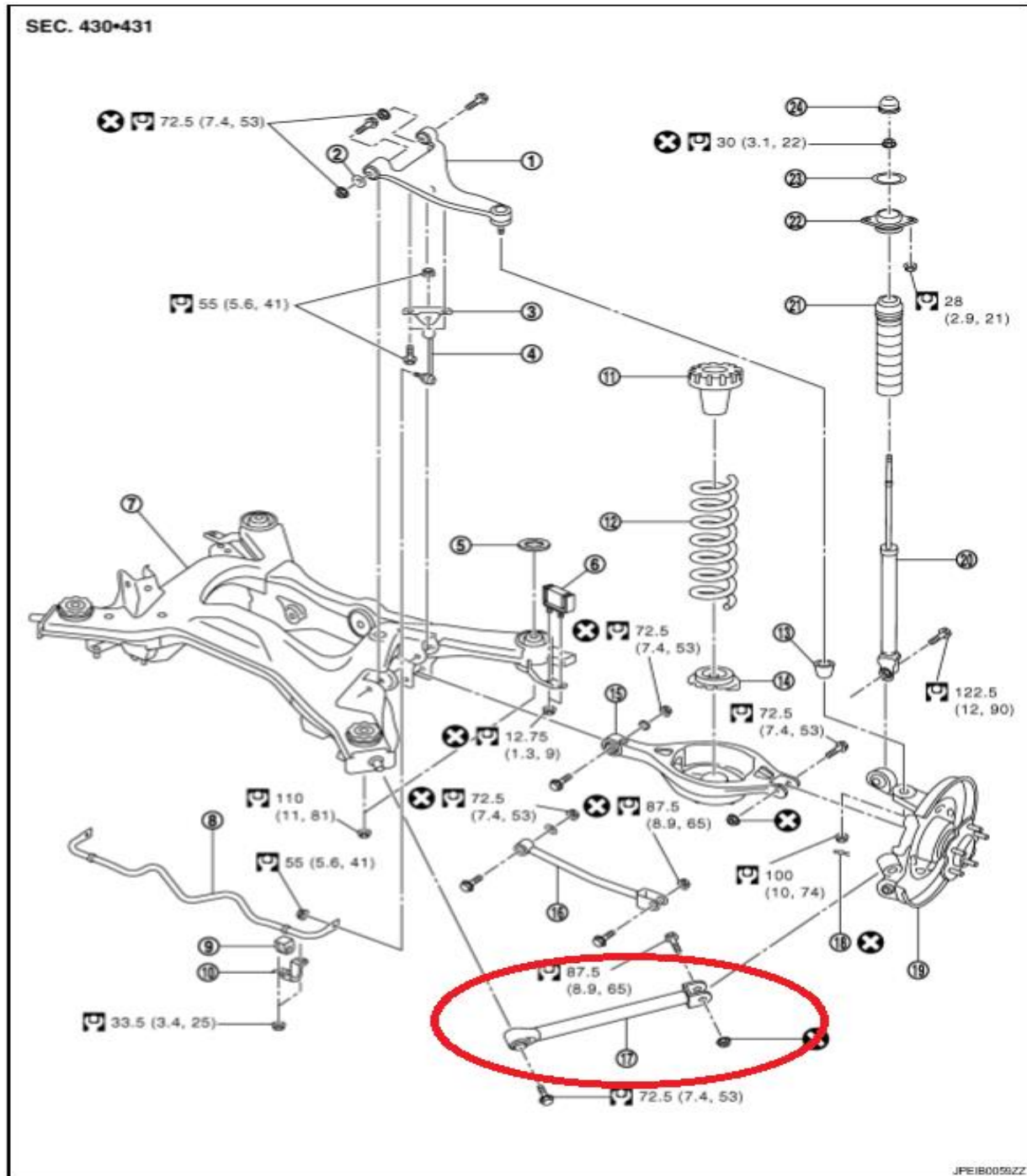

Thank you for your purchase of this SPL Parts performance suspension product. Please follow these instructions exactly to ensure that the product is able to function to the best of its ability, and you can achieve the most performance out of your vehicle.

1. Apply the parking brake and shift your vehicle in park for an automatic transmission or 1st gear for a manual transmission.
2. Jack up the rear of your vehicle so that the rear tires are no longer touching the ground. Place jack stands in factory recommended locations to safeguard both the vehicle and yourself from harm.
3. Remove the rear wheels off of the vehicle and place them to the side.
4. Remove the stock rear traction arm from the subframe and knuckle of the vehicle. The arm is pictured in the above blow up view of the suspension. You must remove the knuckle side first by loosening and removing the bolt, then remove the bolt that holds the subframe end on and slide the arm off.
5. Take the SPL Parts RTR and hold it next to the arm you just removed. Adjust the FK Rod End (6) and Double Adjuster (4) to line up with the bolt holes so that the stock arm and the SPL Parts RTR are the same length. Adjust both the Double Adjuster and the FK Rod End out, not just one or the other. Once the arms are the same length, tighten all Titanium Socket Head Cap Screws (2,3) to 150 **in.-lbs. DO NOT OVERTORQUE.** SPL parts is not liable for any issues due to overtorque.
6. Install the subframe side of the SPL Parts RTR first. You can place the spacer (7) on before or after the rod end. If you put the spacer on after the Rod End (6) this will increase the offset from the wheel, which is better for very wide wheels, and is what is normally suggested. If you put it on before, this will reduce your clearance to your wheels, but will increase the distance you have from the subframe. This is better for if you are shortening the link. Make sure the FK Rod End is in the middle of its articulation when installed onto the subframe. This will ensure that the arm has the ability to move through its suspension travel without binding, and that the FK Rod End will not wear prematurely.
7. Slide the clevis end of the arm over the knuckle, and slide the bolt through. Make sure that the offset of the arm is positioned to give you more clearance to your wheel. If you do not do this it can cause issues with smaller diameter wheels, and can also cause binding based on your alignment. The Titanium Screws (5) should be towards the inside of the vehicle.
8. Tighten the bolt at the subframe to 53 **ft.-lbs.** and the bolt at the knuckle to 65 **ft.-lbs.**

9. Repeat the process on the opposite side of the vehicle.
10. Place the wheels back on the car.
11. Jack up the car and remove the jack stands, then slowly lower the vehicle back down onto the ground.
12. Take your car to a professional alignment shop. Make sure to bring these instructions to confirm that the arm is adjusted correctly.
13. Be safe, and enjoy your new SPL Parts upgrade!

Adjustment

To adjust the alignment of the vehicle, first loosen all of the Titanium Socket Head Cap Screws. Place a wrench around the hex on the Double Adjuster. Turn counterclockwise to shorten the arm, and turn clockwise to lengthen the arm. Once the arm is the desired length, tighten all Titanium Socket Head Cap Screws to 150 **in.-lbs**. Always ensure that the FK Rod End is in the middle of its articulation while at ride height.

SPL Double Adjuster

The hybrid adjuster is what is known as a **double adjuster**. On the outside, the thread is left-handed. On the inside, the thread is right-handed. When the suspension arm is installed, turning the hybrid adjuster will allow you to lengthen/shorten the assembly. When lengthening/shortening, be sure to keep the arm and rod end from freely rotating when you turn the adjuster. Do not make the following mistakes (threading out **only** the adjuster or threading out **only** the rod end):



Overextended adjuster.

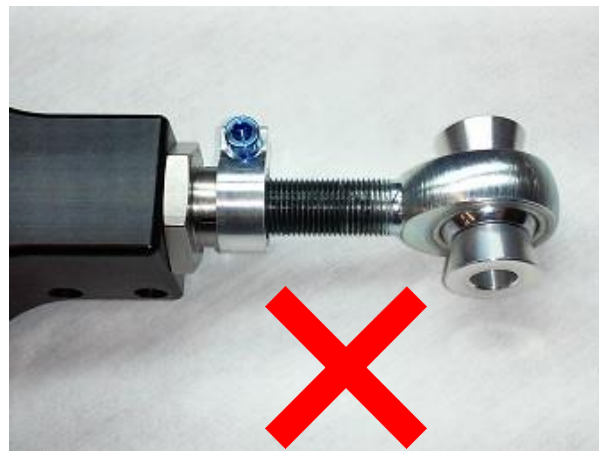

Overextended rod end.

The following picture shows a properly threaded adjuster. The rod end (heim joint) will thread out about 2/3 the length of the adjuster. Note the maximum adjustment limits shown.

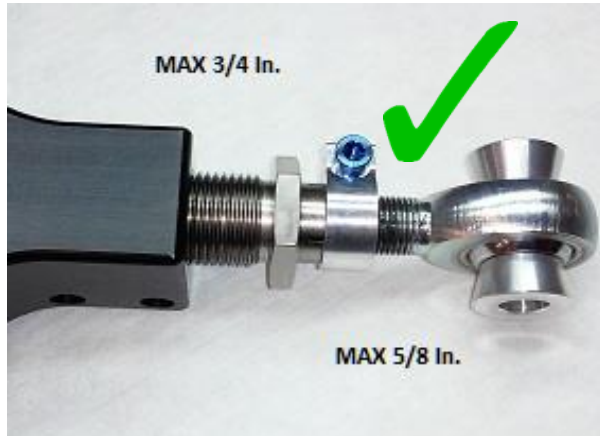

Properly adjusted.

The advantage of the hybrid adjuster is that you can easily keep the rod end bearing centered during and after alignment. Make sure to keep the bearing centered as shown.

You'll notice in the pictures that the threads of the rod end and the adjuster have some dark material on them. That is anti-seize compound we apply to all of our products so that adjustments should be easy and trouble free for quite some time.



ONE-YEAR LIMITED WARRANTY AND DISCLAIMER

All SPL brand products are intended for **Off Road Use Only** and carry a one year limited warranty. See below for details. All other branded products carry their respective manufacturer warranty.

SPL PRO suspension products warranted to be free of defects in material and workmanship for one (1) year from the date of purchase.

If a product fails to meet specifications, SPL PARTS INC will, at its election, repair, replace, or make appropriate adjustment, if SPL PARTS INC determines to its satisfaction that the product is defective in material or workmanship, i.e. contains a defect arising out of the manufacture of the product and not a defect caused by other circumstances, including, but not limited to accident, misuse, abuse, unforeseeable use, neglect, alteration, improper installation, improper adjustment, improper repair, or failure caused by other equipment or interaction with other equipment. SPL PARTS INC is not responsible for labor charges, removal charges, installation, or other incidental or consequential costs. In no event shall the liability of SPL PARTS INC exceed the purchase price of the product.

SPL PARTS INC makes no other warranties, either expressed or implied, including limitation warranties as to merchantability or fitness for a particular purpose. SPL PARTS INC shall not be liable for, and buyer assumes all risk of, any advice or failure to provide advice by SPL PARTS INC to buyer regarding the product or use and installation of product. SPL PARTS INC shall not be liable for any special, incidental or consequential damages.

If the purchaser of the product shall fail to pay when due any portion of the purchase price, or fail to meet any terms required under contract agreed on at time of purchase, all warranties and remedies granted may be terminated.

Using any SPL arm as a tie/strap down point for a dyno session or transport will void the warranty.