

Front Lower Control Street Version Installation Instructions SPL FLCA E9x

NOTE: TWO ASSEMBLIES PER KIT.

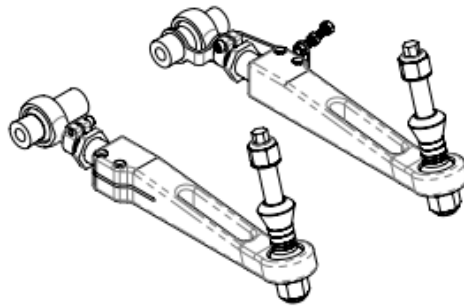

ITEM NO.	PART NUMBER	DESCRIPTION	QTY.
1	22101	ARM, RIGHT BILLET FRONT LOWER, E9X	1
2	90011	DOUBLE ADJUSTER	1
3	90010	CLAMP, SPLIT SHAFT, 5/8	1
4	JM12T-58-18-F1	ROD END	1
5	52001	BOLT	1
6	52002	BOLT	2
7	HIN10T-F1	BEARING, SPHERICAL,	1
8	62002	RETAINING RING	1
9	40033	TAPERED STUD, LOWER CONTROL ARM, BMW	1
10	90504	SPACER, KNUCKLE, F8X	1
11	90113	SPACER, FLAT	2
12	90114	SPACER, FLAT	2
13	53001	WASHER	1
14	54005	NUT, NYLOCK	2
15	90089	SPACER	1
16	90039	SPACER	1
17	31313	BRACKET, RIDE HEIGHT SENSOR, F8X	1
18	JSI-M6	SCREW, JACK, M6	1
19	54027	NUT, HEX, ZNC	2

SPLPARTS CONFIDENTIAL:
THIS DOCUMENT AND THE INFORMATION CONTAINED IN IT ARE
CONFIDENTIAL, AND CANNOT BE COPIED OR DISCLOSED IN WHOLE OR
IN PART WITHOUT THE EXPRESS WRITTEN CONSENT OF SPLPARTS.

SPLPARTS INC.

SIZE	PART NO.	REV.
A	FLCA E9X INS	B
FILE	SCALE	SHEET
	1:8	1 OF 2

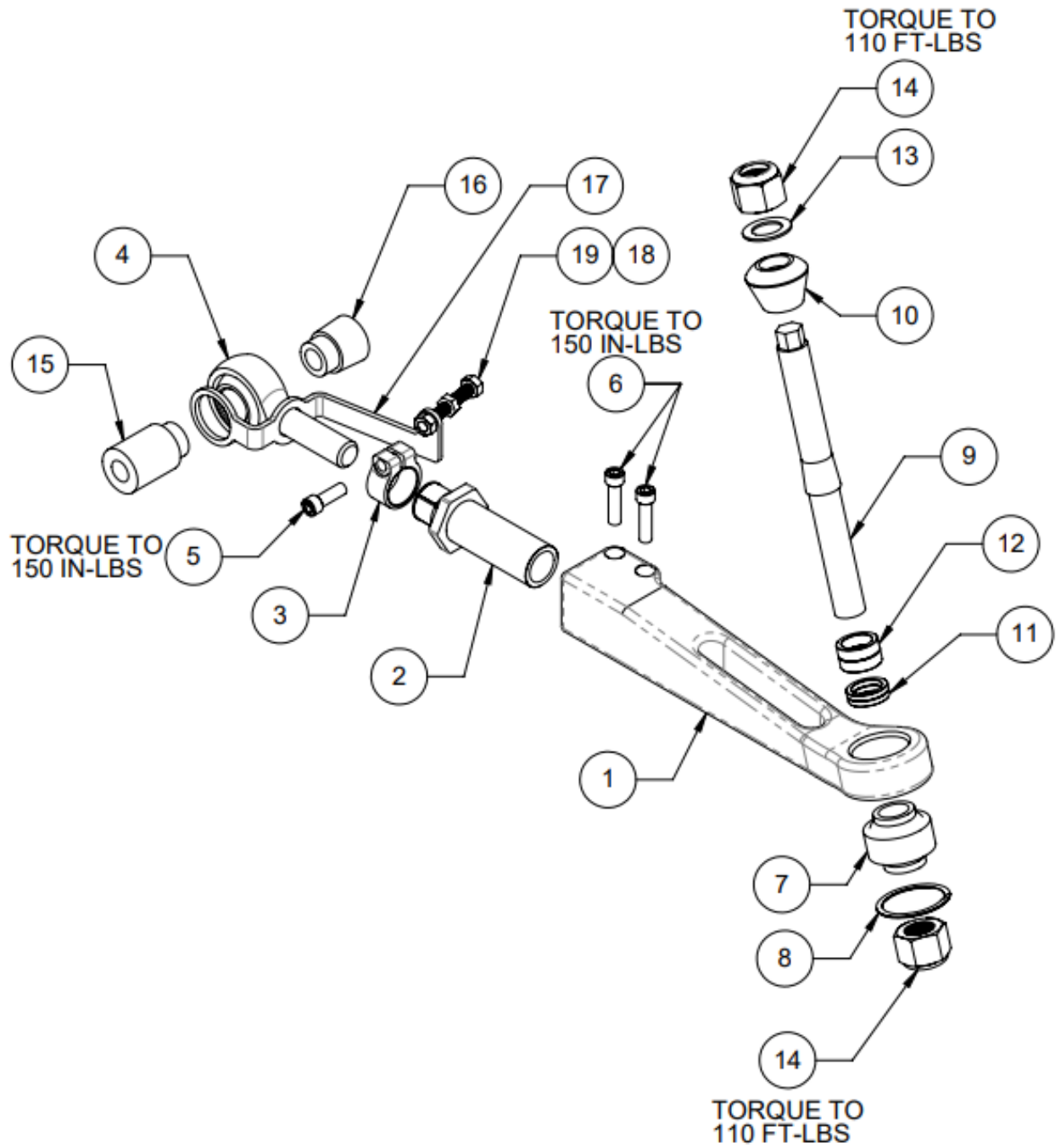

SPLPARTS CONFIDENTIAL:
 THIS DOCUMENT AND THE INFORMATION CONTAINED IN IT ARE
 CONFIDENTIAL, AND CANNOT BE COPIED OR DISCLOSED IN WHOLE OR
 IN PART WITHOUT THE EXPRESS WRITTEN CONSENT OF SPLPARTS.

SPLPARTS INC.			
SIZE A	PART NO. FLCA E9X INS	REV. B	
FILE	SCALE 1:4	SHEET 2 OF 2	

Tools Required

Ratchet, 6mm, 8mm, 16mm, 18mm, 21mm, and T40 Torx Sockets, 12mm, 18mm, 21mm, and 24mm wrench

1. Jack or raise the front end of the car and remove the front wheels.
2. Remove the metal and plastic undertrays that are in your way using 8mm and 16mm sockets.
3. Remove the ball joint nut at steering knuckle using a 21mm wrench. If the ball starts to spin at the knuckle, you may need to use an open face wrench and the T40 torx to remove the nut. Remove the nut and bolt at the subframe end of the arm using an 18mm socket and wrench.
4. Use a prybar to remove arm from steering knuckle, then remove the control arm. The ball joint isn't a press fit, so it should come out fairly easily.
5. Install the height sensor bracket (17) by removing the rod end (4) from the driver's side LCA (the logo faces the front of the vehicle) and slide the bracket onto the rod end, thread the rod end back in, then place the spacer (15) to locate it in position. Install the ride height sensor into the bracket. Attach the OE ride height sensor arm to this bracket. This places the ride height sensor at OE location relative to the lower control arm. The larger spacer (15) faces the front of the vehicle.
6. Place the OEM arm next to the SPL arm, and lengthen the SPL arm to match the OEM arm as closely as possible. Adjust from the hex on the adjuster, do not rotate only the adjuster or only the rod end. This is best done by holding both the rod end and body of the arm in place, and rotating the adjuster by itself. This is explained visually at the end of the instructions in more detail.
7. The stud (19) can now be installed into the knuckle. You will place the tapered spacer (10) onto the stud so that it seats onto the taper. You will then place this assembly with the domed side of the tapered spacer into the knuckle from the bottom. Slide the washer (13) onto the top, then finger tighten the nut (14) until the hex is exposed. Using a 12mm wrench to hold the stud in place, tighten the locknut with a 24mm wrench. Once the taper is tightly engaged, you should be able to place a torque wrench on the assembly and torque to 110 ft-lb.

8. Now you will determine the number of roll center spacers (11, 12) you will use above the bearing (7). Using none mimics OEM roll center and should be used if the car is at stock ride height. Any spacers installed ABOVE the bearing will increase roll center correction. Any spacers not used above the bearing must be placed below the bearing to allow the assembly to be tightened. Do not add more than 1/2" of roll center correction (both of the #12 larger roll center spacers above the bearing), otherwise you risk bending or breaking the assembly. Below are pictures showing how to properly install the stud. Once you have spacer orientation decided, tighten the locknut (14) to 110 ft-lb.



Not all spacers were used



Too many spacers above bearing



Maximum Roll Center Correction

9. Install the SPL Parts Control Arm at subframe end with the OEM bolt where the two FLCA Spacers (9) should fit, then install at the knuckle. **The clamping mechanism on the arm should be facing the rear of the vehicle, with the logo facing forwards. If the arm is installed on the wrong side of the vehicle, you can have contact issues with the swaybar.** Tighten the bolts at the subframe to **74ft. lbs. (100N/M)**
10. If you have a lowered vehicle, you must sweep your suspension from full droop to full compression and lock to lock to ensure the bearing (5) does not go out of articulation anywhere in the suspension travel. Not doing this could result in **dangerous** bearing failure. We suggest removing the spring from the shock/coilover to make sure the suspension is travelling through its full sweep, as the shock should be the limiting factor of your travel, not our arm. Make sure that there are no contact issues anywhere in the sweep as well.
11. Have the car professionally aligned, as replicating the original settings is nearly impossible. It may be necessary to adjust the toe in order to drive the car to an alignment shop if you either added or subtracted camber. Take these instructions with you to ensure that the arm is adjusted correctly.
12. Check all torques after the first 100 and 500 miles of driving, or after your first two sessions at the track if it is a track car, to make sure that nothing has loosened up due to vibrations.

Be safe, and enjoy your new upgrade!

SPL Double Adjuster

The hybrid adjuster is what is known as a **double adjuster**. On the outside, the thread is left-handed. On the inside, the thread is righthanded. When the suspension arm is installed, turning the hybrid adjuster will allow you to lengthen/shorten the assembly.

When lengthening/shortening, be sure to keep the arm and rod end from freely rotating when you turn the adjuster. Do not make the following mistakes (threading out **only** the adjuster or threading out **only** the rod end):



Overextended adjuster



Overextended rod end.



MAX 3/4 In.

MAX 5/8 In.

Properly adjusted.

This picture shows a properly threaded adjuster. The rod end (heim joint) will thread out about 2/3 the length of the adjuster. Note the maximum adjustment limits shown. You'll notice in the pictures that the threads of the rod end and the adjuster have some dark material on them. That is an anti-seize compound we apply to all of our products so that adjustments should be easy and trouble free for quite some time.



The advantage of the hybrid adjuster is that you can easily keep the rod end bearing centered during and after alignment. Make sure to keep the bearing centered as shown.

SPL™ LIMITED WARRANTY¹

What is Covered?: Subject to the terms, exclusions and limitations herein, SPL Parts, Inc. (“SPL”) exclusively warrants to the owner of the vehicle SPL components are initially installed on, SPL will, according to terms herein, repair or replace defects in SPL materials or workmanship that upon SPL’s inspection are determined to exist as of the date of sale to the initial end user/customer (hereafter “Customer”).

- The term of this Limited Warranty shall be twenty four months from SPL delivery to first end user/Customer.

What is Not Covered?: Your SPL Limited Warranty does not cover: (1) defect in a SPL component causing or contributing to damage to the motorized chassis, body, emissions, belting/airbags, electrical system or other vehicle system or component separately warranted or supplied by a manufacturer other than SPL, (2) SPL components used in competition or other events which may involve unforeseen vehicle components, suspension set ups and contact between vehicles and obstacles, (3) damage to SPL components or your vehicle from additions, alterations, or other products or components not supplied by SPL, (4) *damage or degradation of performance from failure to adequately inspect, maintain, adjust or service as recommended or required, damage resulting from improper suspension set-up, loading, accident, collision, vandalism, abuse, misuse, neglect, fire, flood, normal wear, (5) damage caused or related to use of SPL control arms or other parts as a tie-down for dyno testing or transport (6) labor, consequential, incidental, punitive or other damages or costs, including those incurred in removing or delivering your SPL component to SPL for inspection, repair or replacement.*

Obtaining Warranty & Customer Service: For questions or claims contact: SPL Warranty, 30307 Ranch Road 12, Unit 100, Dripping Springs, Texas 78620; Tech@splparts.com. Please have proof of purchase available.

Remedy Limited to Repair/Replacement by SPL. Limited time for Filing Warranty Claims. BINDING, SINGLE CLAIM ARBITRATION-Venue: Upon Customer’s removal and delivery to SPL, SPL inspection and SPL determination of a covered defect, *the exclusive remedy provided hereunder shall at SPL’s option be repair or replacement of the defective SPL component. Written notice of any claim for breach/damages related to this Limited Warranty must be provided SPL within 20 days of customer notice or concern with a defect and in all instances within 30 days of the date your Limited Warranty expires (i.e. not later than twenty-five months from delivery). For separate, valuable consideration received; all claims arising from or related to purchase or use of SPL components shall exclusively be maintained as a separate action by each Customer with jurisdiction, venue and determination applying Texas state law (without reference to treaties or conflict of law provisions) through binding arbitration before a neutral selected by Customer from the JAMS® panel closest to Austin, Texas. To the extent permitted by law, each party shall bear its own costs and fees.*

Other Exclusions –Limitation of Damages - Your Rights Under State Law.

In consideration of the purchase price negotiated, SPL shall not be liable for: *costs incurred by Customer removing, transporting or presenting components to SPL for repair or replacement under this Limited Warranty (expedited or other shipping is Customer’s responsibility), any time loss, rental costs, towing or for any incidental, consequential, punitive or other damages Customer may incur arising or in any way related to Customer’s negotiation, purchase and use of SPL components. Your exclusive remedy hereunder is repair or replacement as described above. By claiming the benefits of this Limited Warranty Customer agrees: (a.) your sole and exclusive remedy in any proceeding for breach of this express Limited Warranty is money damages in an amount equal to the lesser of the purchase price of the covered SPL part or the reasonable cost for material and labor necessary to repair or replace SPL components that Customer proves at arbitration should have been done hereunder but were not; (b.) your sole and exclusive remedy in a proceeding for breach of any applicable implied warranty is money damages in an amount equal to the lesser of the purchase price of the covered SPL part or the amount Customer proves at arbitration equal to the reasonable cost for material and labor necessary to correct the defect(s) in SPL components upon which the finding of breach of implied warranty is based. This Limited Warranty of repair or replacement shall not be construed as a representation or warranty of future performance. The duration of any implied warranty shall be limited to the term of express Limited Warranty provided above.*

No employee or other agent of SPL is authorized to amend or waive this written Limited Warranty or make additional representations or warranties regarding any SPL features, performance, workmanship or materials. This Limited Warranty shall be construed according to Texas Law without reference to treaties or conflict of law principles.

This Limited Warranty gives you specific rights. You may also have other rights that vary from state to state. For example, some states do not allow limitations of how long an implied warranty lasts and/or do not allow the exclusion or limitation of incidental or consequential damages, so the limitations and exclusions herein may not apply to you. All other warranties are hereby disclaimed, except to the extent prohibited by applicable law.

¹ © Copyright licensed to SPL, Parts, Inc.