

Front Tie Rod Ends Kits Installation Instructions SPL TRE R35

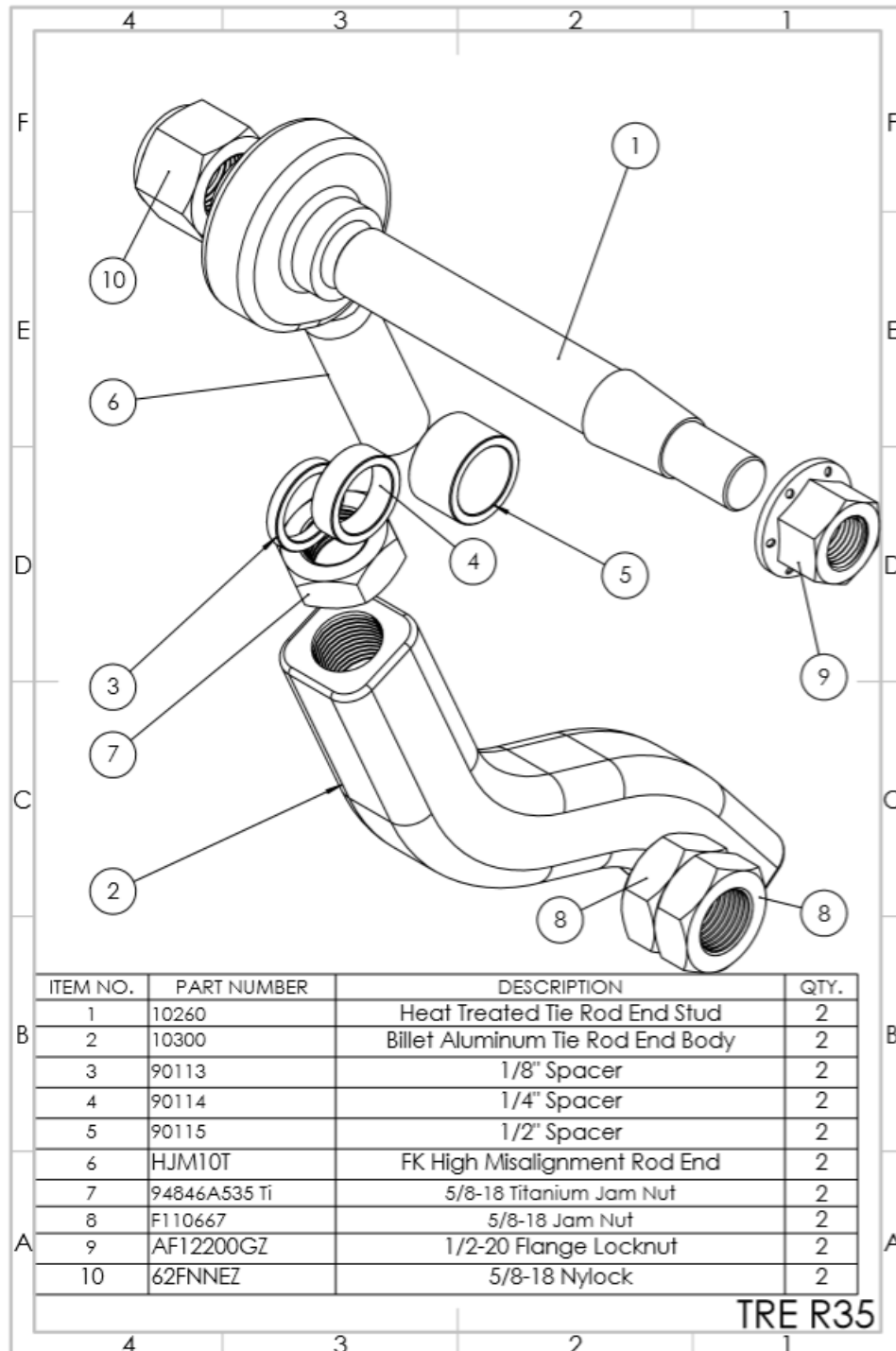

Thank you for your purchase of this SPL Parts performance suspension product. Please follow these instructions exactly to ensure that the product is able to function to the best of its ability, and you can achieve the most performance out of your vehicle.

Note: the curvature of the tie rod end. Match this to the stock item. It is necessary to set tie rod length prior to installation.

Mark your current tie rod positions to make realignment easier. After securely jacking your car up and removing your old tie rod ends, use the following procedure:

1. Use the two supplied silver 5/8-18 Jam Nuts (8) and jam the two nuts together to help hold the Tie Rod End Stud (1). The Blue Titanium Jam Nut (7) is for the FK Rod End (6). Torque the 1/2-20 Flange Locknut (9) on top of the knuckle to **75 ft.-lbs. DO NOT USE IMPACT GUN OR OVERTORQUE** otherwise strength of tie rod end will be severely compromised. *SPL Parts is not liable for any issues due to overtorque.*
2. Install the SPL Parts Tie Rod End onto the inner. Once the Tie Rod is in approximate position, insert the Tie Rod End Stud through the FK Rod End.

There are four Spacers in the kit: 1/8 in (3), two 1/4 in (4), and 1/2 in (5). Use any number or combination of them to achieve the proper bumpsteer setting for your car. Verify there are no clearance issues with the knuckle, subframe, or other suspension arms before putting the car back on the ground. Make sure that the inner tie rod end can articulate freely. The picture below is for illustration purposes only, but it shows proper and improper static position of the rod end bearing. Next, tighten the 5/8-18 Locknut (10) on the bottom of the Tie Rod End Stud to **80 ft.-lbs.** This will take some effort as it is a crimping locknut.



3. Tighten down the 5/8-18 Jam Nut (9) on each end of the Tie Rod End.

Check for binding or any problems by rotating steering wheel lock to lock. Check that the spherical bearing does not bind (the edge of the ball bearing hitting or close to hitting the housing) under any situation as shown in the picture above. After installing, run the suspension through its travel and the

steering rack from lock to lock to make sure there is no contact between the arms.

We strongly urge you to have your car professionally aligned ASAP, or if possible, have these tie rod ends professionally installed. Take these instructions with you to ensure that they are adjusted and aligned properly.

Be safe, and enjoy your new upgrade!

ONE-YEAR LIMITED WARRANTY AND DISCLAIMER

*All SPL brand products are intended for **Off Road Use Only** and carry a one year limited warranty. See below for details. All other branded products carry their respective manufacturer warranty.*

SPL PRO suspension products warranted to be free of defects in material and workmanship for one (1) year from the date of purchase.

If a product fails to meet specifications, SPL PARTS INC will, at its election, repair, replace, or make appropriate adjustment, if SPL PARTS INC determines to its satisfaction that the product is defective in material or workmanship, i.e. contains a defect arising out of the manufacture of the product and not a defect caused by other circumstances, including, but not limited to accident, misuse, abuse, unforeseeable use, neglect, alteration, improper installation, improper adjustment, improper repair, or failure caused by other equipment or interaction with other equipment. SPL PARTS INC is not responsible for labor charges, removal charges, installation, or other incidental or consequential costs. In no event shall the liability of SPL PARTS INC exceed the purchase price of the product.

SPL PARTS INC makes no other warranties, either expressed or implied, including limitation warranties as to merchantability or fitness for a particular purpose. SPL PARTS INC shall not be liable for, and buyer assumes all risk of, any advice or failure to provide advice by SPL PARTS INC to buyer regarding the product or use and installation of product. SPL PARTS INC shall not be liable for any special, incidental or consequential damages.

If the purchaser of the product shall fail to pay when due any portion of the purchase price, or fail to meet any terms required under contract agreed on at time of purchase, all warranties and remedies granted may be terminated.

Using any SPL arm as a tie/strap down point for a dyno session or transport will void the warranty.