

# Subframe Differential Bushings Kit Installation Instructions SPL SDBS Z33

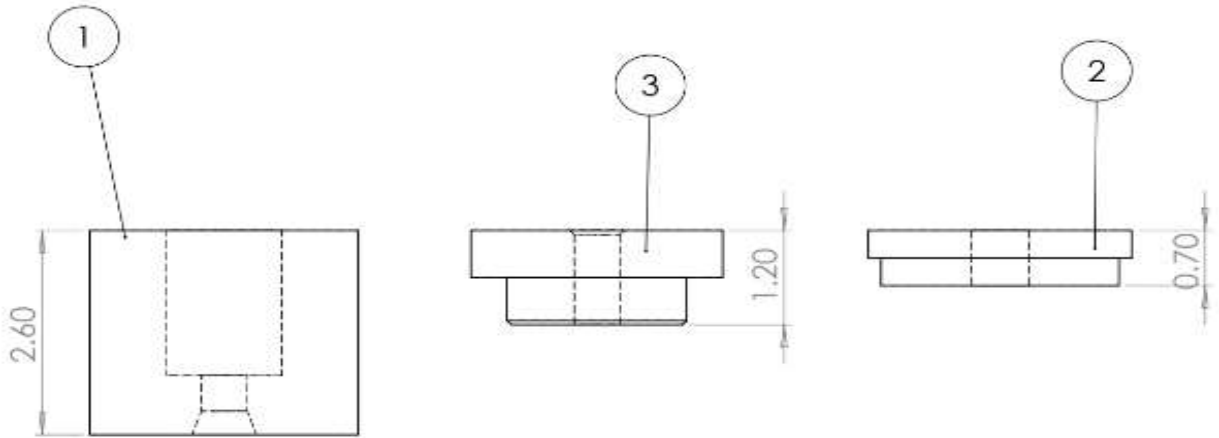

ITEM NO.	PART NUMBER	DESCRIPTION	QTY.
1	10310	Rear Differential Bushing Z33	1
2	10330	Rear Differential Bushing Driver Z33	1
3	10320	Front Differential Bushing Z33	4

## SDBS Z33

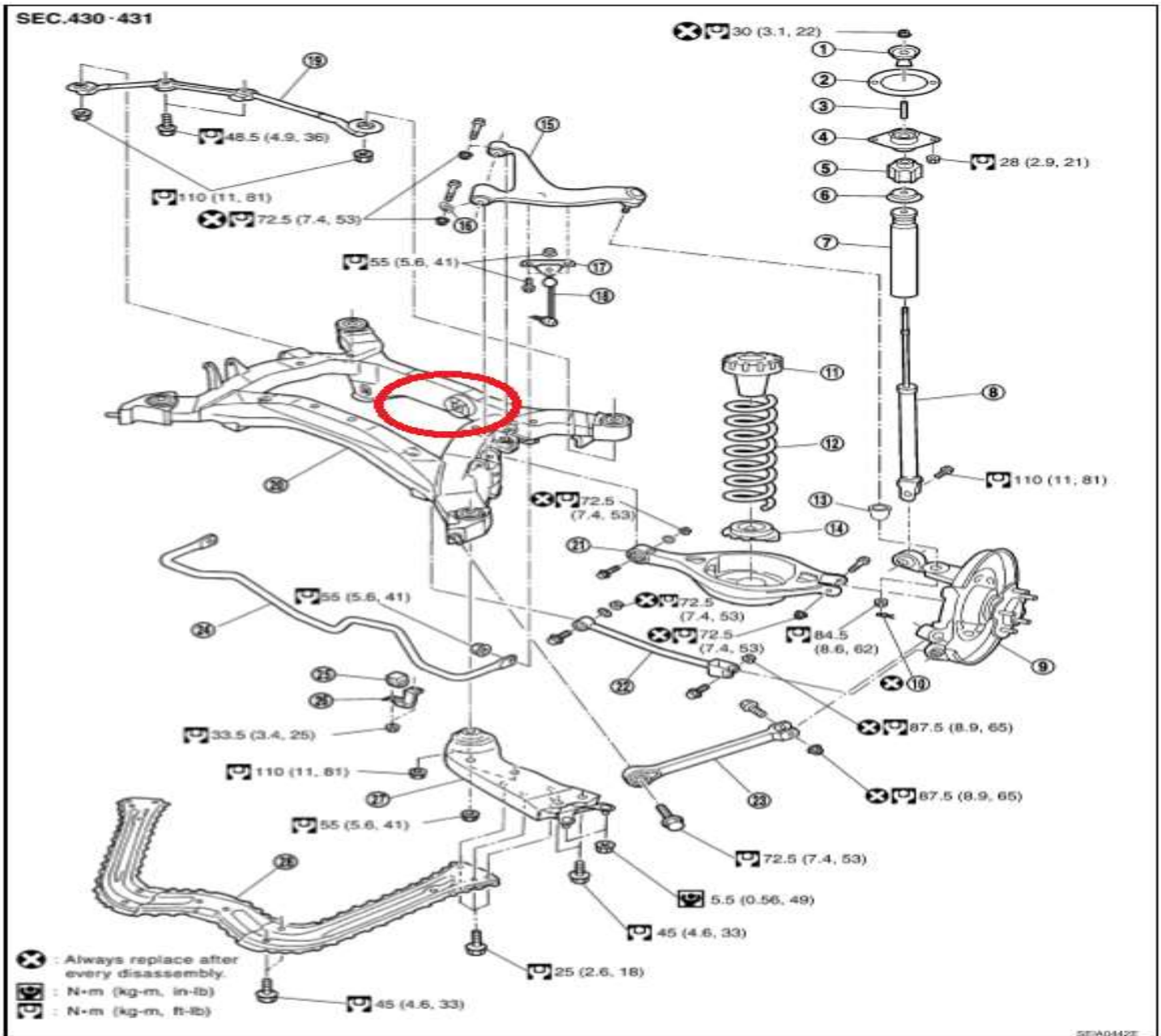

Thank you for your purchase of this SPL performance product. Please follow these instructions exactly to ensure that the product is able to function to the best of its ability, and you can achieve the most performance out of your vehicle.

1. Apply the parking brake on your vehicle. Make sure your car is in neutral, as you will need to be able to rotate the rear axle.
2. Jack up the rear of your vehicle so that the rear tires are no longer touching the ground. Place jack stands in factory recommended locations to ensure that both the vehicle and yourself are safe from harm.

3. Remove the rear wheels off of the vehicle and place them to the side.
4. Begin removing the exhaust past the catalytic converters. This will give you more space to lower the differential.
5. Place a jack underneath the differential to support its weight so it can be lowered once the bolts are loose.
6. Use a 17mm wrench to remove the bolts holding the driveshaft onto the differential.
7. Remove the axles from the differential using a 14mm wrench. Turn the axle as you loosen each bolt to make them easier to access. Once the axle is loosened, wrap an elastic cord or rope around it to hold it in place. Do not let the axle droop as this can damage the assembly.
8. Remove the two bolts from the front differential bushings. The differential should be able to be lowered now. Use the jack that is beneath the differential to slowly and safely remove it from the vehicle. If you have any maintenance you would like to do to your differential other than the bushings, now would be a good time to do so.
9. Press out the bearings on the front of the differential and replace with the supplied front differential bushings (2). Two go on top of the differential, and two go on the bottom.

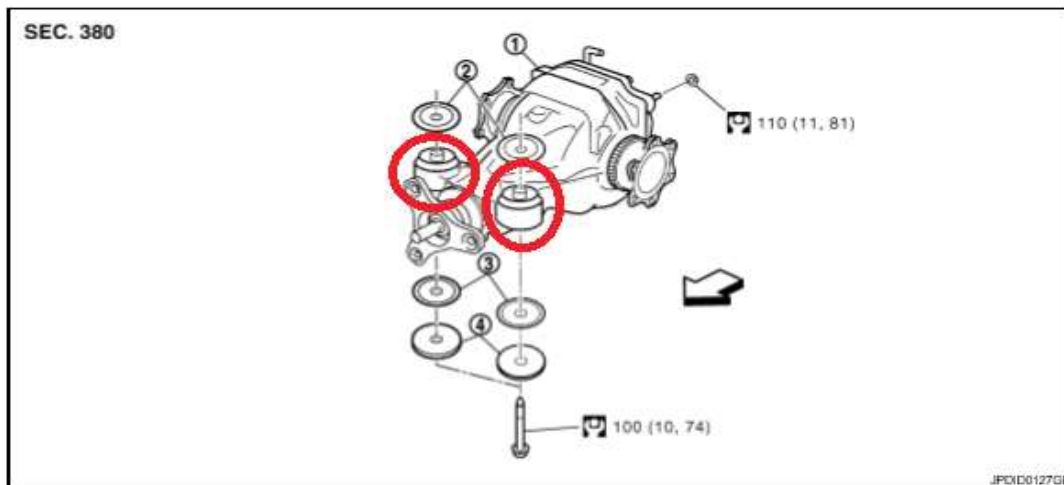

10. Remove the rear differential bushing. This one is much harder to press out, and many times must be removed with a reciprocating saw. Make sure to remove the metal ring that is pressed in around that bushing, otherwise your bearing will not press in. Be very careful when removing this to not take any material from the surface that the bearing will be pressed into.

11. Press the rear bushing (1) into place using the bushing driver (3), making sure that the bushing is pressing in true, and not taking material with it as it is pressed.
12. Reinstall the differential into the subframe, torquing the front differential bolts to **26 ft.-lb.** and the rear differential bolt to **74 ft.-lb.**
13. Reinstall the axles into the differential, torquing each bolt to **52 ft.-lb.**
14. Reinstall the driveshaft into the differential, torquing all bolts to **54 ft.-lb.**
15. Reinstall exhaust that was removed to make room for differential.
16. Reinstall your wheels and lower the car.
17. Be safe, and enjoy your new upgrade!

## **ONE-YEAR LIMITED WARRANTY AND DISCLAIMER**

*All SPL brand products are intended for **Off Road Use Only** and carry a one year limited warranty. See below for details. All other branded products carry their respective manufacturer warranty.*

*SPL PRO suspension products warranted to be free of defects in material and workmanship for one (1) year from the date of purchase.*

*If a product fails to meet specifications, SPL PARTS INC will, at its election, repair, replace, or make appropriate adjustment, if SPL PARTS INC determines to its satisfaction that the product is defective in material or workmanship, i.e. contains a defect arising out of the manufacture of the product and not a defect caused by other circumstances, including, but not limited to accident, misuse, abuse, unforeseeable use, neglect, alteration, improper installation, improper adjustment, improper repair, or failure caused by other equipment or interaction with other equipment. SPL PARTS INC is not responsible for labor charges, removal charges, installation, or other incidental or consequential costs. In no event shall the liability of SPL PARTS INC exceed the purchase price of the product.*

*SPL PARTS INC makes no other warranties, either expressed or implied, including limitation warranties as to merchantability or fitness for a particular purpose. SPL PARTS INC shall not be liable for, and buyer assumes all risk of, any advice or failure to provide advice by SPL PARTS INC to buyer regarding the product or use and installation of product. SPL PARTS INC shall not be liable for any special, incidental or consequential damages.*

*If the purchaser of the product shall fail to pay when due any portion of the purchase price, or fail to meet any terms required under contract agreed on at time of purchase, all warranties and remedies granted may be terminated.*

**Using any SPL arm as a tie/strap down point for a dyno session or transport will void the warranty.**